

MECHANICAL VIBRATION ABSORBER DESIGN FOR PERIODIC EXCITATION

Arvind Singh Tomar

Department of Mechanical Engineering, Amity University, Gwalior

astomar@gwa.amity.edu**ABSTRACT**

TMD and DVA also known as tuned mass damper system and Dynamic vibration absorber system is very useful for the reduction of the amplitude of a vibration signal or some other type of oscillation. In previous days conventional Dynamic vibration absorber consists of three element like spring, mass and Viscous Damper and it is generally mounted to a primary structure as shown in Figure 1(a). Generally most of the mechanical system is fall into the category of periodic vibration rather than simple harmonic excitation. Mathematically, harmonic series are used to analysis the periodic vibration. The first, second and third harmonics contain near by 90 percent of the whole excitation. To suppress above mention periodic excitation, multi-frequency DVA technique is to be done by tuning and adjusting the first, second and third DVA's frequency. The present work of investigation is hence motivated by the Necessity of developing a simple, and passive periodic vibration absorber for periodic excitation. The derived dual beam periodic vibration absorber (Figure b) in this paper will prove itself to meet the necessity and to provide greater applicability for vibration engineers.

Keywords:

Mechanical Vibration Absorber, Vibration Analysis

INTRODUCTION

Vibration monitoring and isolation is very much crucial for avoiding failures of machines [[1]-[3]]. A conventional Dynamic vibration absorber, consists of a spring-mass and damper, is mostly mounted to a primary structure, as shown in Figure 1(a), to absorb the vibration of one single frequency. The fundamental design of an spring-mass and damper can be seen from many vibration textbooks and is not addressed here. The more elaborate works on spring-mass and damper fall into the category of damper design.

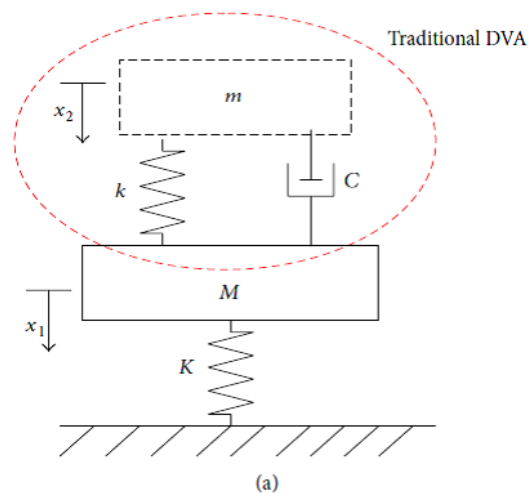

Figure (a) Conventional Dynamic vibration absorber

In order to improve the Dynamic vibration absorber absorption capability, numbers of papers have been aimed at various research aspects; these are control rules derivation, structure's properties and variation, special material and different Dynamic vibration absorber combination.

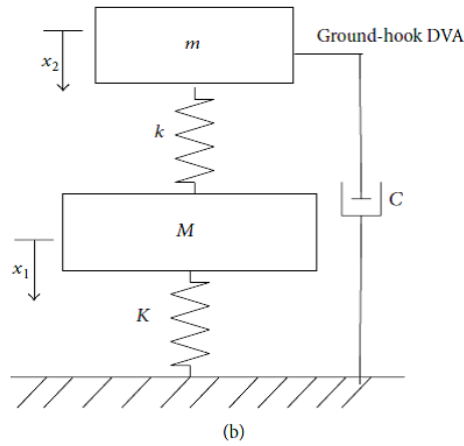

Figure (b) Ground-hook Dynamic vibration absorber

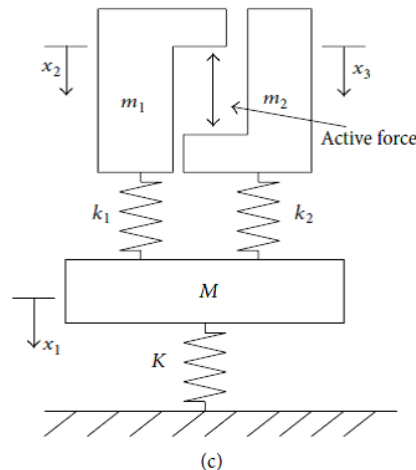

Figure (c) Dual Mass Dynamic vibration absorber

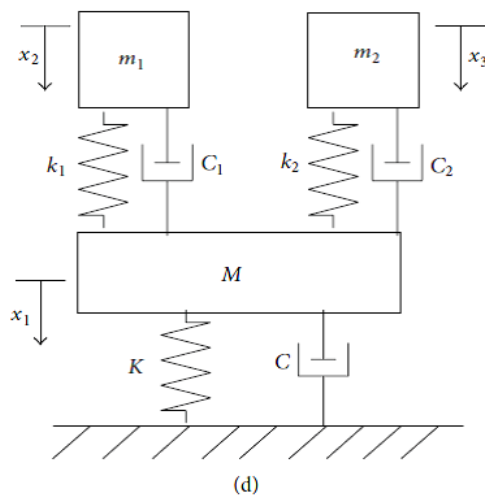

Figure (d) Multi Mode Dynamic vibration absorber

The Dynamic vibration absorber comprised two reaction masses and in between there was a passive/semi active/active damper. This hybrid Dynamic vibration absorber has been proven to have better suppression effect than an ordinary spring-mass and damper, particularly for broadband vibration.

In present situation, most of the mechanical systems are subjected to periodic rather than simple harmonic excitation. Mathematically, periodic excitation is composed of a series of infinite harmonics in integer multiples of base frequency. Nevertheless, only are the first few components significant in mechanical vibration. In general cases, the first three harmonics contain about 90% of the overall excitation. To suppress this periodic excitation, one may employ the multi frequency Dynamic vibration absorber technique and tune three Dynamic vibration absorber frequencies to the first three harmonics. The consequence, yet, will be significant mass loading to the main system. The mass loading effect may be reduced by lowering the Dynamic vibration absorber mass ratio but the cost would be the absorber highly sensitive to excitation frequency variation. The present investigation is hence motivated by the necessity of developing a simple, passive periodic vibration absorber of relatively low mass ratio for periodic excitation. The derived dual beam periodic vibration absorber in this paper will prove itself to meet the goal and to provide significant applicability for vibration engineers.

2. Frequency Equation of PVA

Figure 2 schematically shows the designed PVA mounted on a primary system to resist periodic excitation. M and K denote the primary system's mass and stiffness, respectively. The PVA is composed of two cantilever beams (dual-beam) with an intermediate spring of constant k . The intermediate spring is connected at the position of x_s . For simplicity, though not necessary, the two beams' length is assumed to be the same. ρ_i , A_i , E_i , and I_i , $i = 1, 2$, stand for the i th beam's density, cross-sectional area, Young's modulus, and area moment of inertia, respectively.

The corresponding frequency equation is

$$\alpha(\omega) + \beta(\omega) = 0, \quad \dots\dots\dots(1)$$

Where $\alpha(\omega)$ is the receptance of the first cantilever beam and can be expressed as

$$\alpha(\omega) = \sum_{n=1}^{M_1} \frac{\Phi_n^2(x_s)}{\rho_1 A_1 (\omega_{1n}^2 - \omega^2) \int_0^L \Phi_n^2(x) dx} \quad (2)$$

$$\beta(\omega) = \sum_{n=1}^{M_2} \frac{\Phi_n^2(x_s)}{\rho_2 A_2 (\omega_{2n}^2 - \omega^2) \int_0^L \Phi_n^2(x) dx} + \frac{1}{k}, \quad (3)$$

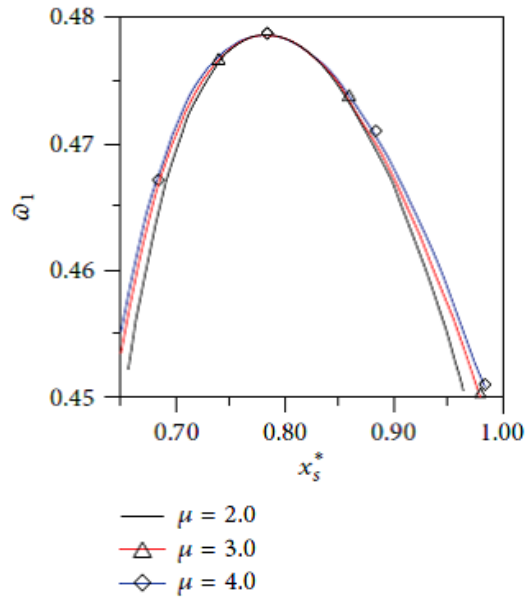

Figure (e) Variations of design parameters to different x_s^*

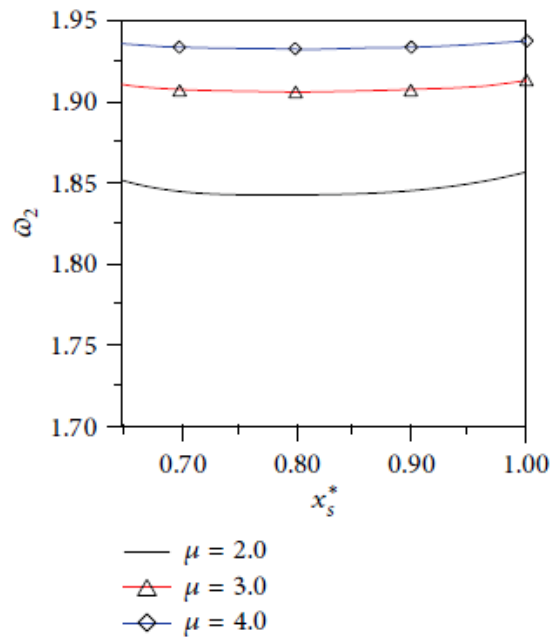

Figure (f) Variations of design parameters to different x_s^*

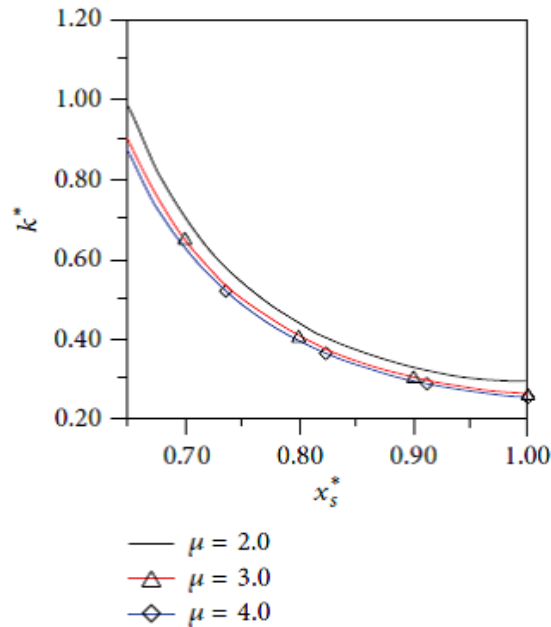

Figure (j) Variations of design parameters to different x_s^*

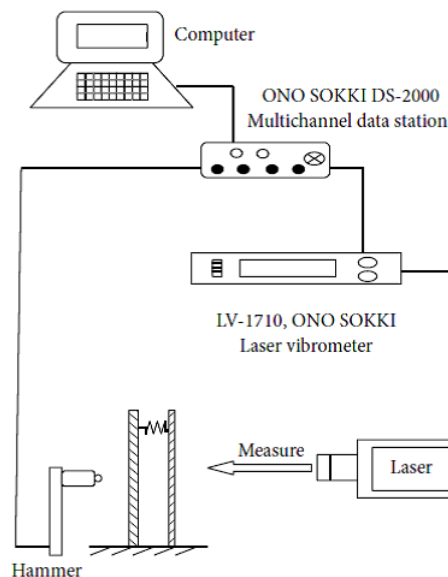

Figure (f) The schematic diagram of PVA experimental test

3. Simulations and Experimental Verification

It is seen that there is room to set two out of five design variables as known values. Prior to doing that, it is helpful to realize the inter correlation between all design variables. We first set the mass ratio (μ), once at a time, at a specific value and look into the correlations between x_s^* and the other three parameters (ω_1 , ω_2 , and k^*). The curves are drawn in Figure g and Figure h. It is seen that all parameters vary with x_s^* in a nonlinear trend. From the shown curves, it is obvious that ω_1 and k^* are more sensitive to x_s^* . ω_2 curves are rather flat relative to x_s^* variations. ω_2 , yet, shows much larger sensitivity (curves farther apart) to μ 's change than ω_1 and k^* do.

These correlations shown in Figure g and Figure h provide us with a reference to determine the design variables, although not in an optimal sense. For example, one may first select appropriate μ and ϖ_2 (most sensitive); then, from its corresponding x_s^* one can continue for suitable ϖ_1 and k^* . The above-mentioned process is just one of many possibilities. Two examples solved by the above process are illustrated and the calculations are given in Table 1.

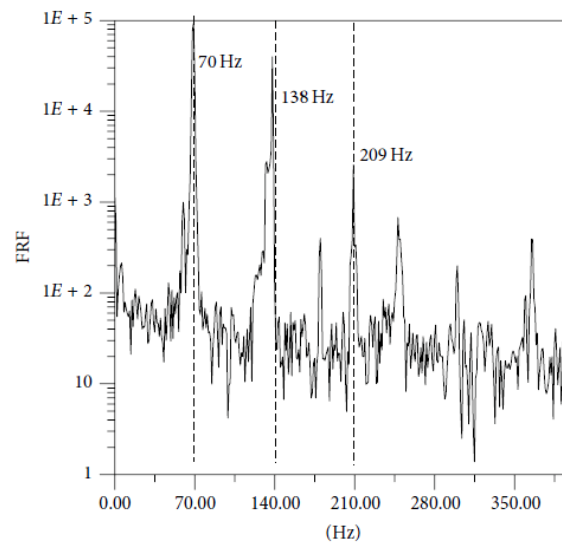

Figure (g) Experimental FRF of (a) specimen A and (b) specimen B.

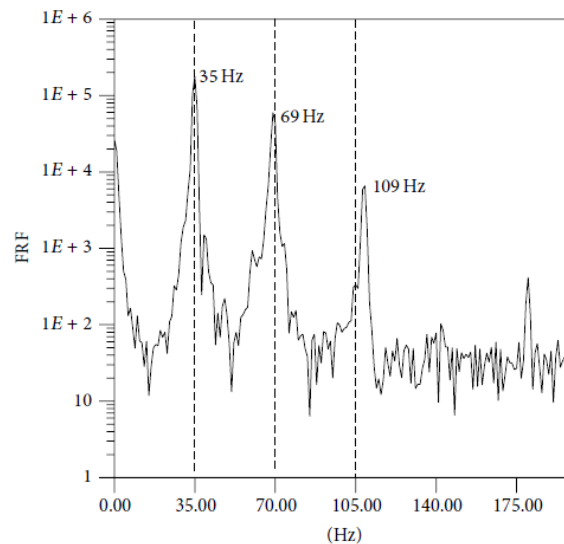

Figure (h) Experimental FRF of (a) specimen A and (b) specimen B.

TABLE 1: The geometrical and material properties of PVA.

(a)

Specimen A		
	First beam (SUS304)	Second beam (Al)
Density (kg/m^3)	$\rho_1 = 7800$	$\rho_2 = 2710$
Modulus ($\times 10^9 \text{ N/m}^2$)	$E_1 = 200$	$E_2 = 69$
Thickness (mm)	$h_1 = 0.88$	$h_2 = 3.68$
Width (mm)	$b_1 = 20.0$	$b_2 = 27.57$
Length (mm)	$L_1 = 175.0$	$L_2 = 175.0$

Spring constant: $k = 0.791 \text{ KN/m}$; connecting location: $x_s = 171.5 \text{ mm}$.
 $f_1 = 70 \text{ Hz}$.

(b)

Specimen B		
	First beam (SUS304)	Second beam (Al)
Density (kg/m^3)	$\rho_1 = 7800$	$\rho_2 = 2710$
Modulus ($\times 10^9 \text{ N/m}^2$)	$E_1 = 200$	$E_2 = 69$
Thickness (mm)	$h_1 = 1.19$	$h_2 = 4.97$
Width (mm)	$b_1 = 25.0$	$b_2 = 34.47$
Length (mm)	$L_1 = 250.0$	$L_2 = 250.0$

Spring constant: $k = 0.8301 \text{ KN/m}$; Connecting location: $x_s = 245.0 \text{ mm}$.
 $f_1 = 35 \text{ Hz}$.

TABLE 2: Simulated response amplitudes due to periodic excitation of $f = 120 \text{ Hz}$.

Wave	Without absorber	With DVA	With PVA
Square wave	0.33	0.012	0.004
		(-28.8 dB)	(-38.3 dB)
Saw-tooth	0.18	0.026	0.007
		(-16.8 dB)	(-28.2 dB)

TABLE 3: Simulated and experimental results with a saw-tooth wave of $f = 55 \text{ Hz}$.

Without absorber experiment	With PVA simulation	With PVA experiment
0.014	0.001 (-22.9 dB)	0.0015 (-19.4 dB)

4. Conclusions

In this paper, a periodic vibration absorber (PVA) of dual beam type is for the first time ever designed, analytically discussed, and experimentally verified. The PVA consists of two cantilever beams interconnected with an intermediate

Discrete spring. When the spring is appropriately chosen and located, the PVA can very effectively attenuate any periodic excitation. The frequency equation of the designed PVA was theoretically derived from the receptance method and subsequently arranged in a general, dimensionless form in terms of five design variables. Enforcing the PVA's resonance frequencies in integer multiples and solving the frequency equation, the PVA's parameters were determined according to the excitation base frequency. This paper demonstrated examples of setting the PVA's first three resonance frequencies in integer multiples of the base frequency and the results

appeared to be accurate by experimental verification. The responses of the primary system with/without the designed PVA were calculated in simulations. As expected, the results showed PVA's excellent absorption effect to periodic excitation. Experiments followed to verify the theoretical calculations and satisfactory agreement has been obtained. From the shown examples, PVA could improve the response amplitude 9.5-11.4dB more, compared to a single DVA. The error of PVA's absorption between simulation and experiment was about 3.5 dB that might be attributed to the design variables' variations and the ignored damping existed in structures. The ability of adjusting spring's stiffness and location to compensate the mismatch of excitation frequency was studied as well. The results showed that PVA could be well tuned if mismatch was less than 3% and the tuned PVA still performed better than a single DVA. The derived PVA in this paper is useful for the audience in vibration engineering and is believed to provide an efficient and effective tool for suppressing periodic vibration of structures.

References

- [1] Sharma, V., & Parey, A. (2017). Frequency domain averaging based experimental evaluation of gear fault without tachometer for fluctuating speed conditions. *Mechanical Systems and Signal Processing*, 85, 278-295.
- [2] Sharma, V., & Parey, A. (2016). Gear crack detection using modified TSA and proposed fault indicators for fluctuating speed conditions. *Measurement*, 90, 560-575.
- [3] Sharma, V., & Parey, A. (2016). A review of gear fault diagnosis using various condition indicators. *Procedia Engineering*, 144, 253-263.
- [4] J. Ormondroyd and J. P. den Hartog, "Theory of the dynamic vibration absorber," *Transactions of the ASME*, vol. 50, pp. 9-22, 1928.
- [5] J. P. den Hartog, *Mechanical Vibration*, McGraw-Hill, New York, NY, USA, 1934.
- [6] J. E. Brock, "A note on the damped vibration absorber," *Journal of Applied Mechanics*, vol. 68, p. A-284, 1946.
- [7] M. B. Ozer and T. J. Royston, "Extending den Hartog's vibration absorber technique to multi-degree-of-freedom systems," *ASME Journal of Vibration and Acoustics*, vol. 127, no. 4, pp. 341-350, 2005.
- [8] M. B. Ozer and T. J. Royston, "Application of Sherman-Morrison matrix inversion formula to damped vibration absorbers attached to multi-degree of freedom systems," *Journal of Sound and Vibration*, vol. 283, no. 3-5, pp. 1235-1249, 2005.
- [9] M. Z. Ren, "A variant design of the dynamic vibration absorber," *Journal of Sound and Vibration*, vol. 245, no. 4, pp. 762-770, 2001.
- [10] W. O. Wong and Y. L. Cheung, "Optimal design of a damped dynamic vibration absorber for vibration control of structure excited by ground motion," *Engineering Structures*, vol. 30, no.1, pp. 282-286, 2008.
- [11] J. Q. Sun, M. R. Jolly, and M. A. Norris, "Passive, adaptive and active tuned vibration absorbers—a survey," *ASME Journal of Mechanical Design*, vol. 117, pp. 234-242, 1995.
- [12] D. Chen and H. Xu, "Dynamic analysis of delayed damper system in engineering structures," *Journal of Sound and Vibration*, vol. 250, no. 4, pp. 609-616, 2002.
- [13] R. A. Burdisso and J. D. Heilmann, "A new dual-reaction mass dynamic vibration absorber actuator for active vibration control," *Journal of Sound and Vibration*, vol. 214, no. 5, pp. 817-831, 1998.
- [14] H. L. Sun, P. Q. Zhang, H. B. Chen, K. Zhang, and X. L. Gong, "Application of dynamic vibration absorbers in structural vibration control under multi-frequency harmonic excitations," *Applied Acoustics*, vol. 69, no. 12, pp. 1361-1367, 2008.
- [15] S. G. Hill and S. D. Snyder, "Design of an adaptive vibration absorber to reduce electrical transformer structural vibration," *ASME Journal of Vibration and Acoustics*, vol. 124, no. 4, pp. 606-611, 2002.
- [16] P. W. Wang and C. C. Cheng, "Design of vibration absorbers for structures subject to multiple-tonal excitations," *ASME Journal of Vibration and Acoustics*, vol. 128, no. 1, pp. 106-114, 2006.
- [17] R. E. D. Bishop and D. C. Johnson, *The Mechanics of Vibration*, Cambridge University Press, Cambridge, UK, 1960.

- [18]K. A. Lin and S. C. Huang, "Modeling and vibration analysis of spinning hard disk and head assembly," *Journal of System Design and Dynamics*, vol. 2, pp. 528–539, 2008.